

ROCK BOARD®

Light Vehicle LED Triangle ID Sign



Part Number: DS-STRI

- Voltage: 12-24v
- Draw: 1.2 Amp @ 24v
- Display Character Height: 122mm
- Application: Light Vehicles, Dozers, Graders, Loaders (Small-Med)
- Display: 1-6 Character Display
- Weight: 4.5kg
- Dimensions: (390mm W x 215mm H x 342mm D)
- Mounting Options:
Bolt-on Part No. DS-STRI-B
Magnet Part No. DS-STRI-M

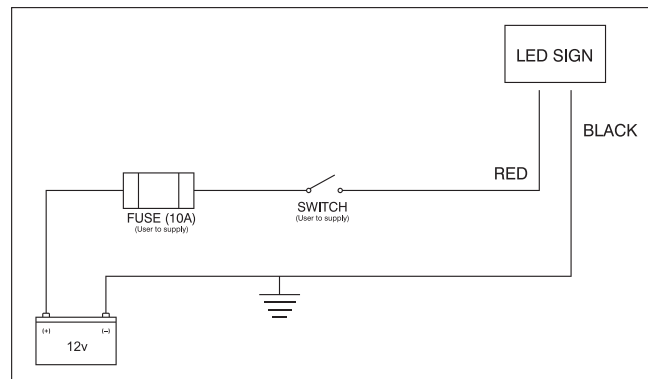

08 9456 1414

afsigns.com.au

sales@afsigns.com.au

16 Brewer Road Canning Vale 6155

1

2

3

4

5

6

7

8

A

B

C

D

E

F

A

B

C

D

E

F

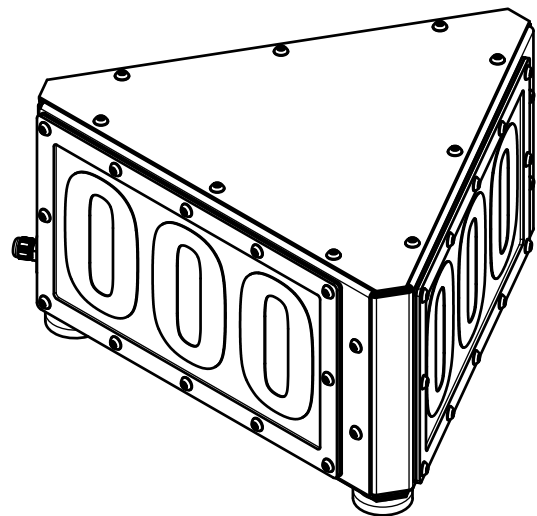
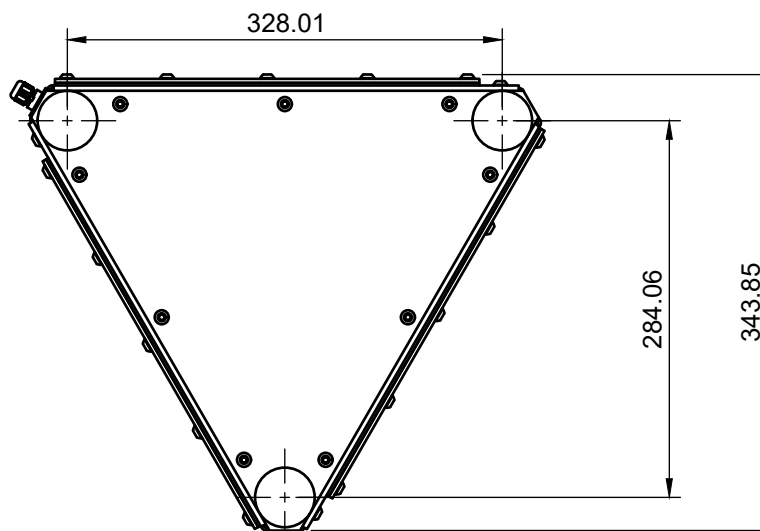
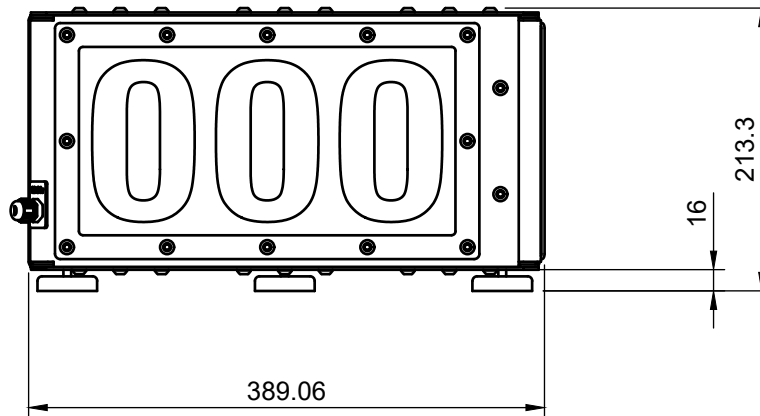

Dept.	Technical reference	Created by	16/04/2024		Approved by
		Document type	Document status		
		Title	DS-STRI-M		
		Rev.	Date of issue	Sheet	
				1/1	

1

2

3

4

5

6

7

8